

**LOW POWER PWM CONTROLLER FOR OFF-LINE BATTERY CHARGER****AP3700****General Description**

The AP3700 is a green-mode pulse width modulation (PWM) controller. It is specially designed for low power applications such as off-line battery chargers, where the needs for low standby power, space saving and low cost are all required. In a battery charger rated 5V/1A, the maximum standby power is only 0.18Watt.

In normal operation, the AP3700 switches on and off at a fixed switching frequency of 60 kHz. With a current limit capability of 420mA, the AP3700 can directly drive the emitter of high voltage NPN transistor or the source of MOSFET. When output power falls below a given level, the IC enters skip cycle mode to reduce power consumption.

The AP3700 also features under-voltage lockout, over-current and short circuit protections.

The AP3700 is available in TO-92 package.

Features

- Current Mode Control with Skip Cycle Capability
- Lower Operating Current: 0.45mA
- Fixed Switching Frequency: 60 kHz
- Frequency Dither for Low EMI: ± 2.5 kHz
- Under-Voltage Lockout Protection
- Over-Current Protection
- Internal Short Circuit Protection
- Higher Output Breakdown Voltage
- Lower Total Cost Solution

Applications

- Battery Chargers
- Off-Line Power Supplies



Figure 1. Package Types of AP3700



Pin Configuration

Z Package
(TO-92)

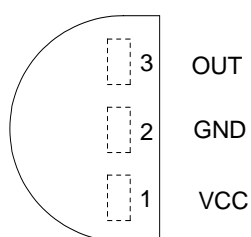

Figure 2. Pin Configuration of AP3700 (Top View)

Pin Description

Pin Number	Pin Name	Function
TO-92		
1	VCC	The power supply of the IC, and is generally connected to opto-coupler's emitter
2	GND	Supply ground
3	OUT	The output pin, connected to the emitter of NPN transistor or the source of MOSFET



LOW POWER PWM CONTROLLER FOR OFF-LINE BATTERY CHARGER **AP3700**

Functional Block Diagram

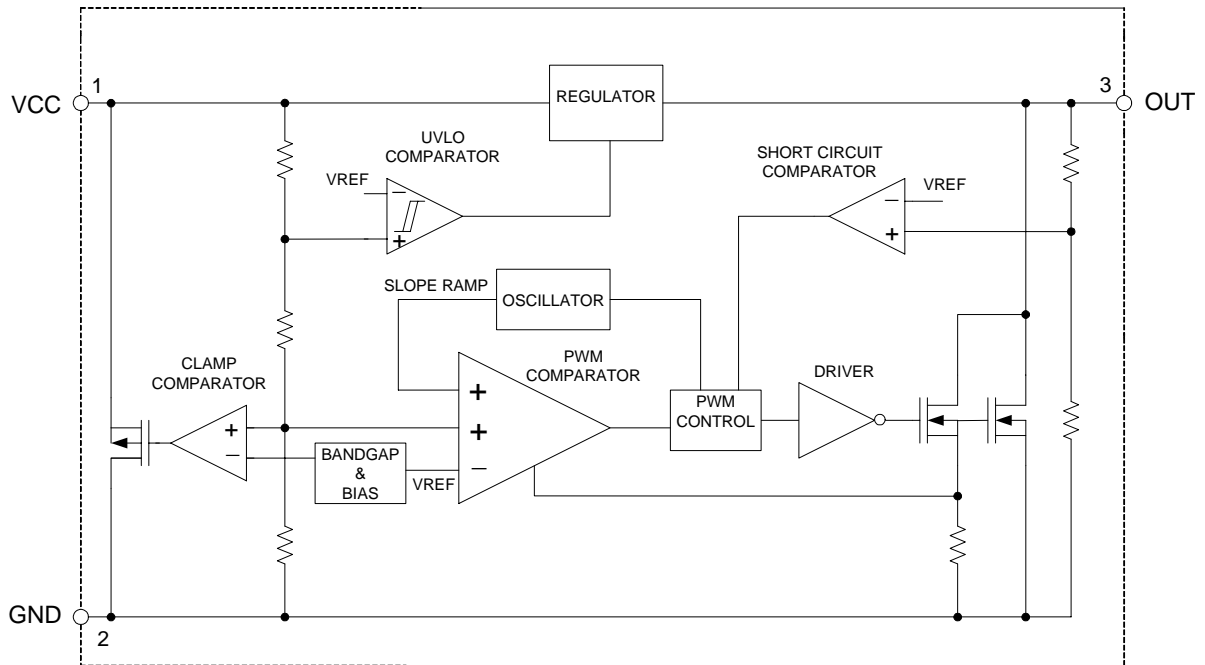
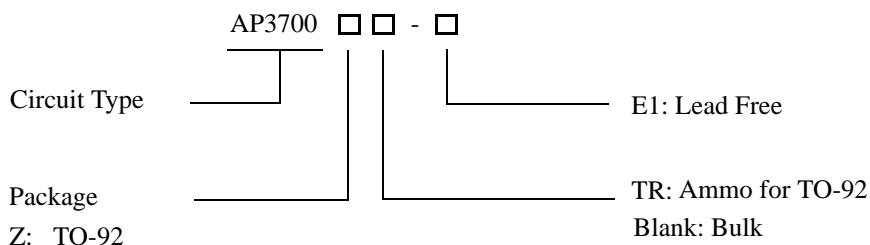

Figure 3. Functional Block Diagram of AP3700

**LOW POWER PWM CONTROLLER FOR OFF-LINE BATTERY CHARGER****AP3700****Ordering Information**

Package	Switching Frequency	Temperature Range	Part Number	Marking ID	Packing Type
TO-92	60kHz	-40 to 85°C	AP3700Z-E1	3700Z-E1	Bulk
			AP3700ZTR-E1	3700Z-E1	Ammo

BCD Semiconductor's Pb-free products, as designated with "E1" suffix in the part number, are RoHS compliant.

Absolute Maximum Ratings (Note 1)

Parameter	Value	Unit
Supply Voltage	-0.3 to 6.0	V
Voltage at OUT	-0.3 to 40	V
Output Current at OUT	Internally limited	A
Power Dissipation	N/A	W
Operating Junction Temperature	150	°C
Storage Temperature	-65 to 150	°C
Lead Temperature (Soldering, 10s)	300	°C
ESD (Machine Model)	200	V

Note 1: Stresses greater than those listed under "Absolute Maximum Ratings" may cause permanent damage to the device. These are stress ratings only, and functional operation of the device at these or any other conditions beyond those indicated under "Recommended Operating Conditions" is not implied. Exposure to "Absolute Maximum Ratings" for extended periods may affect device reliability.



LOW POWER PWM CONTROLLER FOR OFF-LINE BATTERY CHARGER AP3700

Electrical Characteristics

($V_{CC}=4V$, $T_J=25^{\circ}C$, unless otherwise specified.)

Parameter	Symbol	Conditions	Min	Typ	Max	Unit
UVLO SECTION						
Start-up Voltage	$V_{TH(ST)}$		5.00	5.25	5.50	V
Minimal Operating Voltage	$V_{OPR(Min)}$		3.4	3.65	3.9	V
STANDBY CURRENT SECTION						
Start-up Current	I_{ST}	$V_{CC}=4V$		0.22	0.4	mA
Operating Current	$I_{CC(OPR)}$			0.45	0.7	
V_{CC} Zener Voltage	V_Z	$I_{CC}=10mA$	6	6.3		V
Dynamic Impedance	R_{VCC}	$V_{CC}=3.8$ to $4.8V$		18		k Ω
INTERNAL OSCILLATOR						
Switching Frequency	F_{SW}		50	60	75	kHz
Frequency Dither			± 2	± 2.5	± 3	kHz
Temperature Stability				5	8	%
DRIVE OUTPUT SECTION						
OUT Start-up Voltage	V_{ST}			8.5	11	V
Short Circuit Threshold Voltage	V_{SC}			6		V
Rise Time	T_R	$C_L=1nF$, 15Ω pull-up		60		ns
Fall Time	T_F	$C_L=1nF$, 15Ω pull-up		30		
Maximum Duty Cycle	D_{MAX}	$V_{OPR(Min)} + 0.2V$	67	75	84	%
Minimum Duty Cycle		$V_{CC}=V_{TH(ST)}-0.2V$		3		
Driver OUT On-Resistance	R_{OUT}	$I_{OUT}=0.06A$		3		Ω
Switch Off Current (OUT)		Driver off, $V_{OUT}=10V$		20	40	μA
Effective Current Limit	I_{LIM}	$V_{CC} = V_{OPR}+0.1V$	420			mA
OUT Current Coefficient	G_A			-0.3		A/V



LOW POWER PWM CONTROLLER FOR OFF-LINE BATTERY CHARGER

AP3700

Typical Performance Characteristics

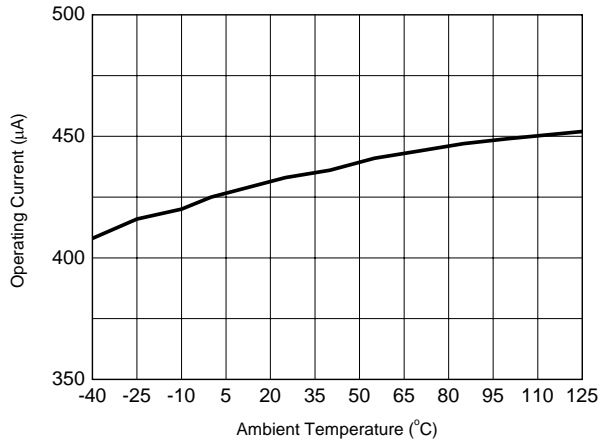

Figure 4. Operating Current vs. Ambient Temperature

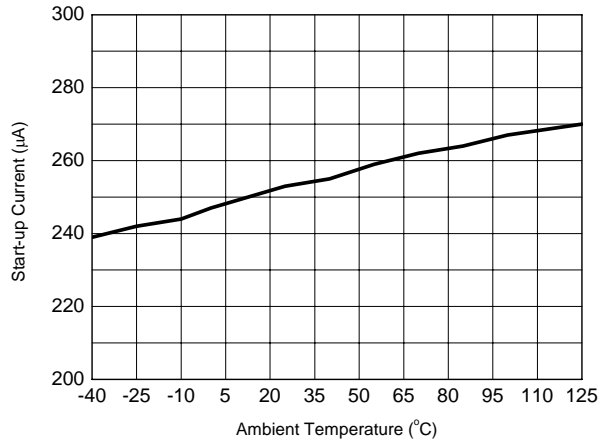

Figure 5. Start-up Current vs. Ambient Temperature

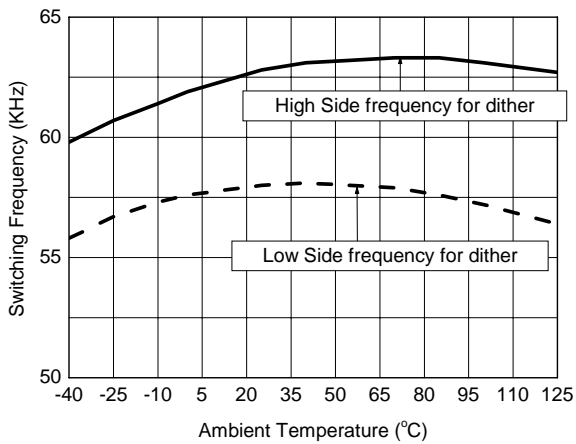

Figure 6. Switching Frequency vs. Ambient Temperature

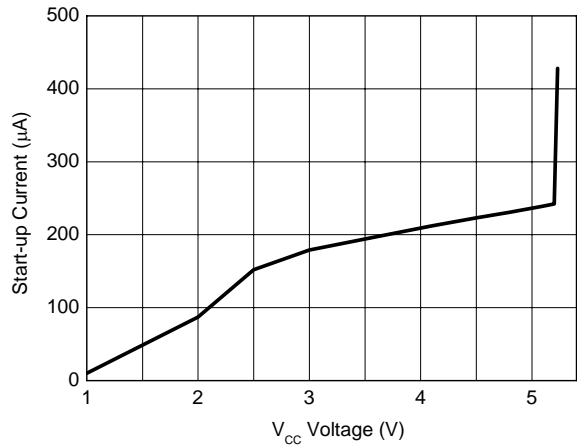

Figure 7. Start-up Current vs. V_{CC} Voltage



Function Description

1. Startup Circuit

Figure 3 is the functional block diagram of AP3700, and there are 3 external pins: the VCC pin, the OUT pin and GND pin. In typical application shown by Figure 10, the VCC pin is used for both bias supply and feedback control. The OUT pin directly drives external NPN transistor or MOSFET, and also provides initial bias power for UVLO comparator. When the IC works in PWM mode, the auxiliary winding will supply the V_{CC} enough operating current.

Figure 8 shows the start-up sequence of the V_{CC} and the V_{OUT} .

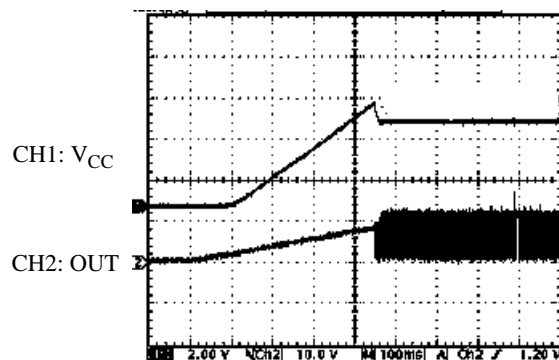

Figure 8. Start-up Sequence of V_{CC} and V_{OUT}

2. V_{CC} /Feedback Control

An opto-coupler and secondary constant voltage/current controller consists of voltage feedback network. When load is heavy, the voltage on VCC will be lower to enlarge duty cycle; on the contrary, if load drops, the voltage on VCC will rise to reduce duty cycle.

3. Frequency Dither

Frequency dither is performed by periodically spreading a single switching frequency into adjacent frequency band, so the peak energy is spread. This technique can improve EMI by reducing both quasi-peak and average EMI emissions.

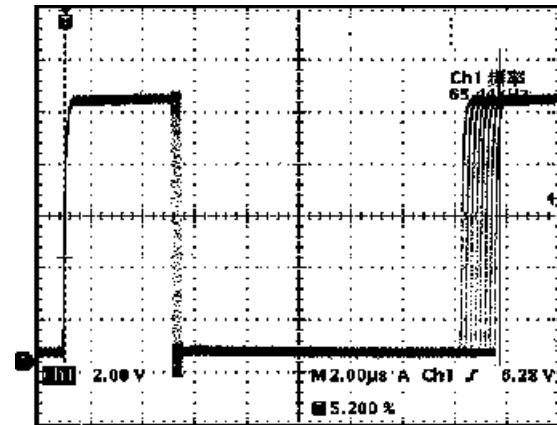

Figure 9. Frequency Dither Influences the Switching Cycle

AP3700 has reference switching frequency of 60 kHz, and its frequency deviation is ± 2.5 kHz in period of 2ms. Figure 9 shows the frequency dither influence to the waveform.

4. Current Limit Control

The AP3700 employs current mode control to improve transient response and voltage stability. In Figure 10, the external inductor current through the OUT pin is converted to a voltage by an internal resistor, and this voltage will participate to control duty cycle and peak inductor current.



LOW POWER PWM CONTROLLER FOR OFF-LINE BATTERY CHARGER

AP3700

Typical Application

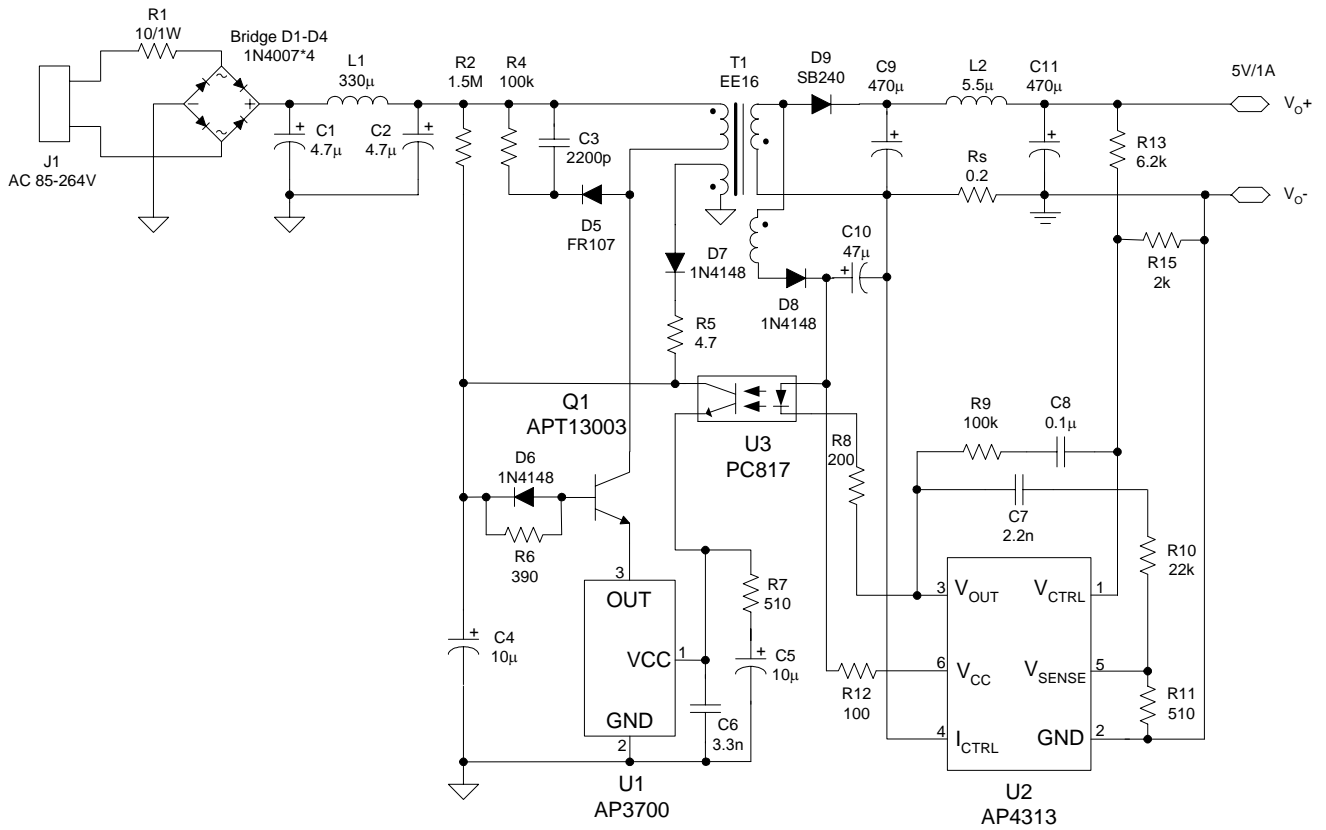

Figure 10. 5V/1A Output for Battery Charger of Mobile Phone



Mechanical Dimensions

TO-92

Unit: mm(inch)

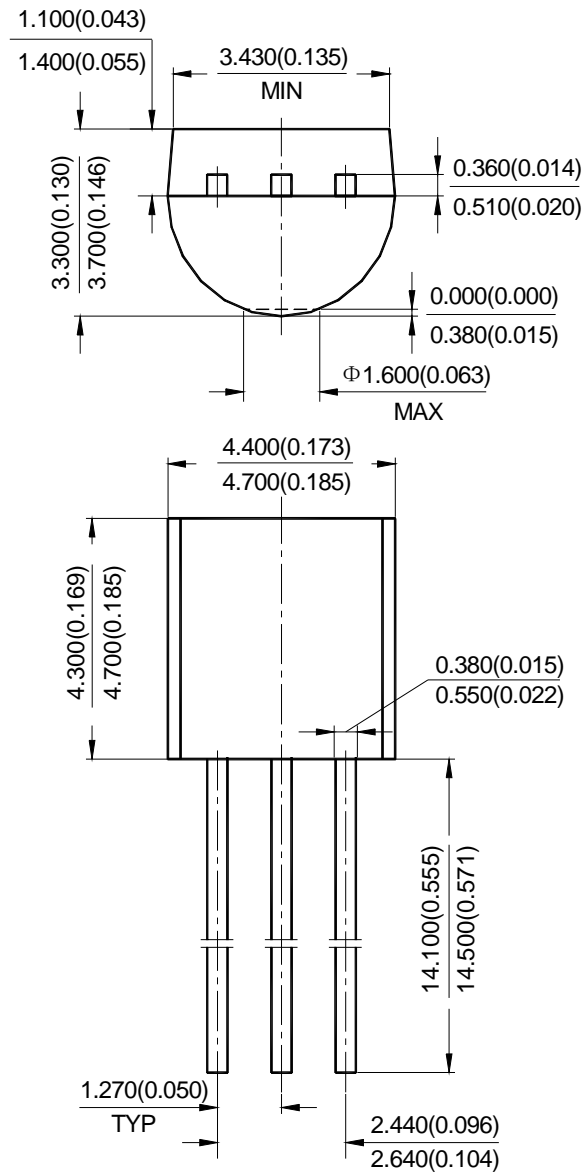



BCD Semiconductor Manufacturing Limited

<http://www.bcdsemi.com>

IMPORTANT NOTICE

BCD Semiconductor Manufacturing Limited reserves the right to make changes without further notice to any products or specifications herein. BCD Semiconductor Manufacturing Limited does not assume any responsibility for use of any its products for any particular purpose, nor does BCD Semiconductor Manufacturing Limited assume any liability arising out of the application or use of any its products or circuits. BCD Semiconductor Manufacturing Limited does not convey any license under its patent rights or other rights nor the rights of others.

MAIN SITE

BCD Semiconductor Manufacturing Limited

- Wafer Fab

Shanghai SIM-BCD Semiconductor Manufacturing Limited

800, Yi Shan Road, Shanghai 200233, China

Tel: +86-21-6485 1491, Fax: +86-21-5450 0008

BCD Semiconductor Manufacturing Limited

- IC Design Group

Advanced Analog Circuits (Shanghai) Corporation

8F Zone B, 900, Yi Shan Road, Shanghai 200233, China

Tel: +86-21-6495 9539, Fax: +86-21-6485 9673

REGIONAL SALES OFFICE

Shenzhen Office

Shanghai SIM-BCD Semiconductor Manufacturing Co., Ltd. Shenzhen Office

Advanced Analog Circuits (Shanghai) Corporation Shenzhen Office

Room E, 5F, Noble Center, No.1006, 3rd Fuzhong Road, Futian District, Shenzhen 518026, China

Tel: +86-755-8826 7951

Fax: +86-755-8826 7865

Taiwan Office

BCD Semiconductor (Taiwan) Company Limited

4F, 298-1, Rui Guang Road, Nei-Hu District, Taipei,

Taiwan

Tel: +886-2-2656 2808

Fax: +886-2-2656 2806

USA Office

BCD Semiconductor Corporation

30920 Huntwood Ave. Hayward,

CA 94544, U.S.A

Tel : +1-510-324-2988

Fax: +1-510-324-2788